

To ensure your application is reviewed in a timely manner, please find your project type from the options below for a list of additional submittal requirements. Please ensure all materials submitted are clear and legible.

If you are applying for a commercial, industrial, institutional or multi-unit (>4 units) residential development, please refer to the Non-Residential Development Permit Application Package.

REQUIRED FOR ALL DEVELOPMENT PERMIT APPLICATIONS	
✓	Required Submittal
	Completed Application Form
	Application Fee
	Applicant and Registered Owner signatures on the Application Form
	or
	Signature of Applicant and a Letter of Authorization from the Registered Owner

ADDITIONAL SUBMITTALS BY PROJECT TYPE			
ADDITION (INCLUDING COVERED DECK)		SECONDARY SUITE	
✓	Required Submittal	✓	Required Submittal
	Site Plan (a Real Property Report can be used) indicating proposed location, size and setbacks to property lines and other buildings on site		Site Plan (a Real Property Report can be used) indicating location and stall size of available parking on site
	Drawings of proposed addition		Floor Plan of proposed suite indicating room dimensions and uses, and location of doors and windows
UNCOVERED DECK		ACCESSORY BUILDING (SHED, GARAGE, GAZEBO, ETC.)	
✓	Required Submittal	✓	Required Submittal
	Site Plan (a Real Property Report can be used) indicating proposed location, size and setbacks to property lines		Site Plan (a Real Property Report can be used) indicating proposed location, size and setbacks to property lines and other buildings on site
			Accessory Building Details Sheet (separate form)
✓	Required Submittal		Drawings of proposed building (optional) indicating overall height
	Home Business Supporting Information (separate form)		
NEW HOME CONSTRUCTION			
✓	Required Submittal		
	Surveyor's Plot Plan (Hard Copy or Digital) showing lot elevations, sanity service & storm sewer invert and driveway location		
	Two (2) Hard Copies or Digital Copy of Drawings including floor and elevation plans		
	Proof of New Home Warranty Insurance		
	Proof of Provincial Builder Licensing		

**Separate forms can be obtained on our website or by contacting Planning & Development*

Development Application No.: _____

OFFICE USE ONLY

Application Fee: _____ DB MC VISA CHQ CSH ONLINE Receipt No.: _____ Land Use District: _____
Date Received: _____ Rec'd By: _____ Deemed Complete: _____ DC By: _____

IMPORTANT: THIS IS NOT A BUILDING PERMIT

Any approvals granted regarding this application does not excuse the applicant from complying with the requirements of any Federal, Provincial, or other Municipal legislation or the conditions of any easement, restrictive covenant or agreement affecting the buildings or lands.

APPLICANT/LANDOWNER INFORMATION

Applicant Name:			Registered Owner Name(s): <i>(If different from Applicant)</i>		
Mailing Address:			Mailing Address:		
City:	Province:	Postal Code:	City:	Province:	Postal Code:
Phone:	Cell:		Phone:	Cell:	
Email:			Email:		

PROJECT LOCATION

Municipal Address			Roll Number			
Lot:	Block	Plan	Section	Township	Range	Meridian

PROPOSED DEVELOPMENT

Existing Use of Land or Building(s) on the Property:

Describe Proposed Development:

Project Value:

SIGNATURE

I/We hereby make application for a development permit under the provisions of the Town of Westlock Land Use Bylaw in accordance with the plans and supporting information submitted herewithin and which forms part of this application.

I/We agree that in the event of a Development Permit being granted for this application, I/We will comply in all aspects with the conditions subject to which it is granted and any Bylaws or legislation pertinent to this application and the proposed development.

I/We understand that any development and construction may not proceed prior to permit issuance and any commencement of development or construction prior to permit issuance is subject to penalties and/or a Stop Work Order.

Applicant Signature	Property Owner Signature
Print Name	Print Name



Applicant: Owner Contractor

Permit Number: 345345-_____-B_____

Application Date: _____

Development Permit: _____

Construction Value (Labor + Materials: \$ _____ Estimated Start Date: _____ Estimated Completed Date: _____

PROPERTY OWNER INFORMATION					
Owner Name:		Mailing Address:			City:
Province:	Postal Code:	Phone:	Email:		
I hereby declare that I am the owner of the premises in/on which the work will be conducted, and reside on the property. I am doing the work myself, and assume responsibility for compliance with the applicable Act and Regulations					
_____ Owners' Signature					
CONTRACTOR INFORMATION					
Contractor Name:		Mailing Address:			City:
Province:	Postal Code:	Phone:	Email:		
_____ Contractor/Architect/Engineer Name					
_____ Signature					
_____ Business License Number					

The Permit holder hereby certifies that this installation will be completed in accordance with the Alberta Safety Codes Act & Regulations. Section 25(1) of the Permit Regulations AR 204/2007 of the Safety Codes Act RSZ 20000, Chapter S-1 states "A permit expires if the undertaking to which it applies: (a) is not commenced within 90 days from the date of issue of the permit, (b) is suspended or abandoned for a period of 120 days. This permit expires after 90 days if work has not started and an extension has not been requested. Please note that a one-time ninety (90) day extension can be considered when applied for in writing prior to a permit expiry date.

PROJECT LOCATION						
Municipal Address				Roll Number		
Lot:	Block	Plan	Section	Township	Range	Meridian
PROJECT INFORMATION						
Building Occupancy: <input type="checkbox"/> Single Detached Dwelling <input type="checkbox"/> Semi/Multi-Attached Dwelling <input type="checkbox"/> High Density Residential <input type="checkbox"/> Commercial <input type="checkbox"/> Industrial <input type="checkbox"/> Institutional <input type="checkbox"/> Other: _____		Type of Work: <input type="checkbox"/> New Construction <input type="checkbox"/> Relocation <input type="checkbox"/> Addition <input type="checkbox"/> Renovation <input type="checkbox"/> Demolition <input type="checkbox"/> Manufactured/RTM Home <input type="checkbox"/> Other: _____		Building Area in Sq. Ft: Number of Stories: _____ Main Floor: _____ 2nd Floor: _____ Basement: _____ Garage: _____ Deck: _____ Total Area: _____		New Home Construction Projects Only: NHW#: _____ Provincial Builder License#: _____
Description of Work: _____						

PLEASE CONTACT SUPERIOR SAFETY CODES FOR INSPECTIONS, MINIMUM TWO WORKING DAYS NOTICE.

OFFICE USE ONLY	
Permit Fee:	SCO Name:
SCC Levy (\$4.50 or 4%): <i>whichever is greater, max. \$560</i>	SCO Signature:
Total:	Designation No.:
<input type="checkbox"/> DB <input type="checkbox"/> MC <input type="checkbox"/> VISA <input type="checkbox"/> CHQ <input type="checkbox"/> CSH <input type="checkbox"/> ONLINE	Receipt No.:
	Permit Issue Date:

RESIDENTIAL ADDITIONS



PERMITS & INSPECTIONS

PERMIT NO.: _____

OWNERS NAME: _____

PROJECT LOCATION: _____

To be Completed and attached to the Building Permit Application Form

A. Roof

Roof Material _____
 Roof Sheathing _____
 Rafters _____ x _____ Spacing _____
 or Engineered Trusses _____ Spacing _____

B. Ceiling

Insulation _____
 Vapour Barrier _____
 Ceiling Joist _____ Spacing _____
 Ceiling Material _____

C. Walls

Double top plate
 _____ x _____ Studs at _____ on Center
 Single bottom plate
 Insulation _____
 Vapour Barrier _____
 Wall Sheathing _____
 Exterior wall finish _____
 Interior finish _____

D. Beam

_____ x _____ ply _____ x _____ species
 Supported at _____ on center
 _____ columns
 _____ x _____ x _____ footing

E. Foundation

_____ inch Concrete foundation wall at least _____ ft below grad
 Footing _____ wide _____ thick

F. Floor

_____ x underlay _____ sub floor
 _____ x _____ Joist at _____ on center Species Bridging at 7" on centre

G. Crawl Space

2" sand on 6 mil poly or equal
 Ventilation _____
 Insulation _____

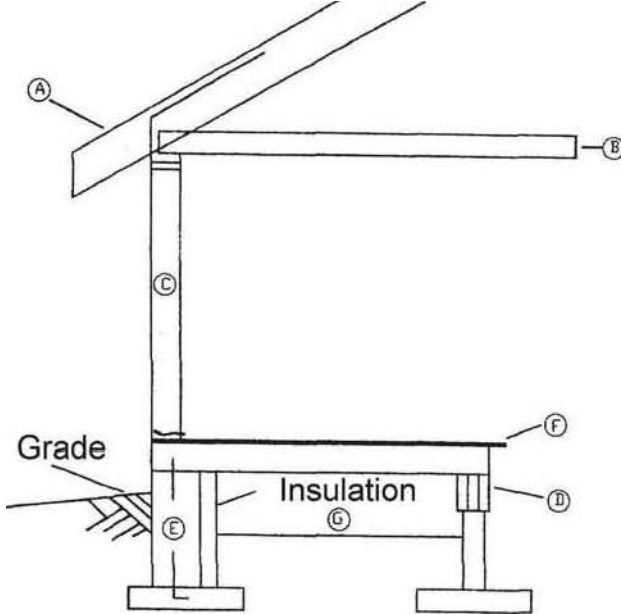

Comments: